

II

(Non-legislative acts)

ACTS ADOPTED BY BODIES CREATED BY INTERNATIONAL AGREEMENTS

Only the original UN/ECE texts have legal effect under international public law. The status and date of entry into force of this Regulation should be checked in the latest version of the UN/ECE status document

TRANS/WP.29/343, available at:

<http://www.unece.org/trans/main/wp29/wp29wgs/wp29gen/wp29fdocstts.html>

UN Regulation No 153 – Uniform provisions concerning the approval of vehicles with regard to fuel system integrity and safety of electric power train in the event of a rear-end collision [2021/386]

Date of entry into force: 22 January 2021

This document is meant purely as documentation tool. The authentic and legally binding text is: ECE/TRANS/WP.29/2020/76.

CONTENTS

REGULATION

1. Scope
2. Definitions
3. Application for approval
4. Approval
5. Requirements
6. Test
7. Modification and extension of approval of a vehicle type
8. Conformity of production
9. Penalties for non-conformity of production
10. Production definitively discontinued
11. Names and addresses of the Technical Services responsible for conducting approval tests and of the Type Approval Authorities

ANNEXES

- 1 Communication
- 2 Examples of arrangements of approval marks
- 3 Procedure for rear-end impact test
- 4 Test conditions and procedures for the assessment of post-crash hydrogen fuel system
- 5 Test procedures for vehicles equipped with electric power train

1. SCOPE

This Regulation applies to vehicles of category M₁ ⁽¹⁾ with a total permissible mass not exceeding 3 500 kg and to vehicles of category N₁ with regard to fuel system integrity and safety of electric power train operating on high voltage in the event of a rear-end collision.

2. DEFINITIONS

For the purpose of this Regulation:

2.1. 'Vehicle type' means a category of power-driven vehicles which do not differ in such essential respects as:

2.1.1. The length and width of the vehicle in so far as they have an effect on the results of the impact test prescribed in this Regulation.

2.1.2. The structure, dimensions, lines and materials of the part of the vehicle rearward of the transverse plane through the 'R' point of the rearmost seat.

2.1.3. The lines and inside dimensions of the passenger compartment in so far as they have an effect on the results of the impact test prescribed in this Regulation.

2.1.4. The siting (front, rear or centre) and the orientation (transversal or longitudinal) of the engine, in so far as they have a negative effect on the result of the impact test procedure as prescribed in this Regulation.

2.1.5. The unladen mass, in so far as there is a negative effect on the result of the impact test prescribed in this Regulation.

2.1.6. The locations of the REESS, in so far as they have a negative effect on the result of the impact test prescribed in this Regulation.

2.1.7. The structure, shape, dimensions and materials (metal/plastic) of the tank(s).

2.1.8. The position of the tank(s) in the vehicle in so far as it has a negative effect on the requirements of paragraph 5.2.1.

2.1.9. The characteristics and location of the fuel feed system (pump, filters, etc.).

2.2. 'Passenger compartment' means the space for occupant accommodation, bounded by the roof, floor, side walls, doors, outside glazing, front bulkhead and rear bulkhead, or rear gate, as well as by the electrical protection barriers and enclosures provided for protecting the occupants from direct contact with high voltage live parts.

2.3. 'Unladen mass' means the mass of the vehicle in running order, unoccupied and unladen but complete with fuel, coolant, lubricant, tools and a spare wheel (if provided as standard equipment by the vehicle manufacturer).

2.4. 'Tank' means the tank(s) designed to contain the liquid fuel, as defined in paragraph 2.6 or compressed hydrogen gas, used primarily for the propulsion of the vehicle excluding its accessories (filler pipe, if it is a separate element, filler hole, cap, gauge, connections to the engine or to compensate interior excess pressure, etc.);

⁽¹⁾ As defined in the Consolidated Resolution on the Construction of Vehicles (R.E.3.), document ECE/TRANS/WP.29/78/Rev.6, para. 2. – www.unece.org/trans/main/wp29/wp29wgs/wp29gen/wp29resolutions.html

- 2.5. 'Capacity of the fuel tank' means the fuel-tank capacity as specified by the manufacturer.
- 2.6. 'Liquid fuel' means a fuel which is liquid in normal conditions of temperature and pressure.
- 2.7. 'High voltage' means the classification of an electric component or circuit, if its working voltage is > 60 V and $\leq 1\,500$ V direct current (DC) or > 30 V and $\leq 1\,000$ V alternating current (AC) root – mean – square (rms).
- 2.8. 'Rechargeable electrical energy storage system (REESS)' means the rechargeable energy storage system that provides electric energy for propulsion.
- A battery whose primary use is to supply power for starting the engine and/or lighting and/or other vehicle auxiliary systems is not considered as a REESS [Primary use in this context means that more than 50 per cent of the energy from the battery is used for starting the engine and/or lighting and/or other vehicle auxiliary systems over an appropriate driving cycle, e.g. WLTC for M_1 and N_1].
- 2.9. 'Electrical protection barrier' means the part providing protection against any direct contact to the high voltage live parts.
- 2.10. 'Electric power train' means the electrical circuit which includes the traction motor(s), and may also include the REESS, the electric energy conversion system, the electronic converters, the associated wiring harness and connectors, and the coupling system for charging the REESS.
- 2.11. 'Live parts' means conductive part(s) intended to be electrically energized under normal operating conditions.
- 2.12. 'Exposed conductive part' means the conductive part which can be touched under the provisions of the protection degree IPXXB which is not normally energized, but which can become electrically energized under isolation failure conditions. This includes parts under a cover that can be removed without using tools.
- 2.13. 'Direct contact' means the contact of persons with high voltage live parts.
- 2.14. 'Indirect contact' means the contact of persons with exposed conductive parts.
- 2.15. 'Protection degree IPXXB' means protection from contact with high voltage live parts provided by either an electrical protection barrier or an enclosure and tested using a Jointed Test Finger (protection degree IPXXB) as described in paragraph 4 of Annex 5.
- 2.16. 'Working voltage' means the highest value of an electrical circuit voltage root-mean-square (rms), specified by the manufacturer, which may occur between any conductive parts in open circuit conditions or under normal operating conditions. If the electrical circuit is divided by galvanic isolation, the working voltage is defined for each divided circuit, respectively.
- 2.17. 'Coupling system for charging the Rechargeable Electrical Energy Storage System (REESS)' means the electrical circuit used for charging the REESS from an external electrical power supply including the vehicle inlet.
- 2.18. 'Electrical chassis' means a set made of conductive parts electrically linked together, whose electrical potential is taken as reference.
- 2.19. 'Electrical circuit' means an assembly of connected high voltage live parts which is designed to be electrically energized in normal operation.
- 2.20. 'Electric energy conversion system' means a system (e.g. fuel cell) that generates and provides electric energy for electric propulsion.

- 2.21. 'Electronic converter' means a device capable of controlling and/or converting electric power for electric propulsion.
- 2.22. 'Enclosure' means the part enclosing the internal units and providing protection against any direct contact.
- 2.23. 'High Voltage Bus' means the electrical circuit, including the coupling system for charging the REESS that operates on a high voltage. Where electrical circuits are galvanically connected to each other and fulfil the specific voltage condition, only the components or parts of the electric circuit that operate on high voltage are classified as a high voltage bus.
- 2.24. 'Solid insulator' means the insulating coating of wiring harnesses, provided in order to cover and prevent the high voltage live parts from any direct contact.
- 2.25. 'Automatic disconnect' means a device that when triggered, conductively separates the electrical energy sources from the rest of the high voltage circuit of the electric power train.
- 2.26. 'Open type traction battery' means a type of battery requiring liquid and generating hydrogen gas released to the atmosphere.
- 2.27. 'Aqueous electrolyte' means an electrolyte based on water solvent for the compounds (e.g. acids, bases) which provides conducting ions after its dissociation.
- 2.28. 'Electrolyte leakage' means the escape of electrolyte from REESS in the form of liquid.
- 2.29. 'Non-aqueous electrolyte' means an electrolyte not based on water as the solvent.
- 2.30. 'Normal operating conditions' includes operating modes and conditions that can reasonably be encountered during normal operation of the vehicle including driving at legal speeds, parking or idling in traffic, as well as, charging using chargers that are compatible with the specific charging ports installed on the vehicle. It does not include, conditions where the vehicle is damaged, either by a crash, road debris or vandalism, subjected to fire or water submersion, or in a state where service and or maintenance is needed or being performed.
- 2.31. 'Specific voltage condition' means the condition that the maximum voltage of a galvanically connected electrical circuit between a DC live part and any other live part (DC or AC) is ≤ 30 V AC (rms) and ≤ 60 V DC.
- Note:* When a DC live part of such an electrical circuit is connected to chassis and the specific voltage condition applies, the maximum voltage between any live part and the electrical chassis is ≤ 30 V AC (rms) and ≤ 60 V DC.

3. APPLICATION FOR APPROVAL

- 3.1. The application for approval of a vehicle type with regard to fuel system integrity and with regard to the safety of electric power train operating on high voltage in the event of rear-end collision shall be submitted by the vehicle manufacturer or by their duly accredited representative in accordance with the procedure set out in Schedule 3 of the Agreement (E/ECE/TRANS/505/Rev.3).
- 3.2. A model of the information document is given in Annex 1 – Appendix 1.

4. APPROVAL

4.1. If the vehicle submitted for approval pursuant to this Regulation meets the requirements of this Regulation, approval of that vehicle type shall be granted.

4.1.1. The Technical Service appointed in accordance with paragraph 11 below shall check whether the required conditions have been satisfied.

4.1.2. In case of doubt, account shall be taken, when verifying the conformity of the vehicle to the requirements of this Regulation, of any data or test results provided by the manufacturer which can be taken into consideration in validating the approval test carried out by the Technical Service.

4.2. An approval number shall be assigned to each type approved in accordance with Schedule 4 of the Agreement (E/ECE/TRANS/505/Rev.3).

4.3. Notice of approval or of extension or of refusal or withdrawal of approval or production definitely discontinued of a vehicle type pursuant to this Regulation shall be communicated to the Contracting Parties to the Agreement which apply this Regulation by means of a form conforming to the model in Annex 1 to this Regulation.

4.4. There shall be affixed, conspicuously and in a readily accessible place specified on the approval form, to every vehicle conforming to a vehicle type approved under this Regulation, an international approval mark conforming to the model given in Annex 2 consisting of:

4.4.1. A circle surrounding the letter 'E' followed by the distinguishing number of the country which has granted approval ⁽²⁾;

4.4.2. the number of this Regulation, followed by the letter 'R', a dash and the approval number to the right of the circle prescribed in paragraph 4.4.1.

4.5. If the vehicle conforms to a vehicle type approved, under one or more other UN Regulations annexed to the Agreement, in the country which has granted approval under this Regulation, the symbol prescribed in paragraph 4.4.1 need not be repeated; in such a case the additional numbers and symbols of all the UN Regulations under which approval has been granted in the country which has granted approval under this Regulation shall be placed in vertical columns to the right of the symbol prescribed in paragraph 4.4.1.

4.6. The approval mark shall be clearly legible and be indelible.

5. REQUIREMENTS

5.1. When the vehicle has undergone the test referred to in paragraph 6 below, the provisions in paragraph 5.2 shall be fulfilled.

A vehicle with all parts of the fuel system installed in front of the midpoint of the wheelbase is deemed to fulfil the provisions in paragraph 5.2.1.

A vehicle with all parts of the electric power train operating on high voltage installed in front of the midpoint of the wheelbase is deemed to fulfil the provisions in paragraph 5.2.2.

5.2. Following the test conducted in accordance with the procedure laid down in Annex 3, Annex 4 and Annex 5 to this Regulation, following provisions with regard to fuel system integrity and safety of electric power train shall be fulfilled:

⁽²⁾ The distinguishing numbers of the Contracting Parties to the 1958 Agreement are reproduced in Annex 3 to the Consolidated Resolution on the Construction of Vehicles (R.E.3), document ECE/TRANS/WP.29/78/Rev. 6, Annex 3- www.unece.org/trans/main/wp29/wp29wgs/wp29gen/wp29resolutions.html.

- 5.2.1. In the case of a vehicle propelled by liquid fuel, compliance with paragraphs 5.2.1.1 to 5.2.1.2 shall be shown.
- In case of compressed hydrogen-fuelled vehicles, compliance with paragraphs 5.2.1.3 to 5.2.1.5 shall be shown.
- 5.2.1.1. No more than slight leakage of liquid from the fuel-feed installation shall occur on collision.
- 5.2.1.2. If there is continuous leakage of liquid from the fuel-feed installation after the collision, the rate of leakage shall not exceed 30 g/min; if the liquid from the fuel-feed system mixes with liquids from the other systems and the various liquids cannot easily be separated and identified, all the liquids collected shall be taken into account in evaluating the continuous leakage.
- 5.2.1.3. The hydrogen leakage rate (V_{H_2}) determined in accordance with either, paragraph 4 of Annex 4 for hydrogen, or paragraph 5 of Annex 4 for helium, shall not exceed an average of 118 NL per minute for the time interval, Δt minutes, after the crash.
- 5.2.1.4. The gas (hydrogen or helium as applicable) concentration by volume in air values determined for the passenger and luggage compartments in accordance with paragraph 6 of Annex 4, shall not exceed 4,0 per cent for hydrogen or 3,0 per cent for helium, at any time throughout the 60 minute post-crash measurement period. This requirement is satisfied if it is confirmed that the shut-off valve of each hydrogen storage system has closed within 5 seconds of first vehicle contact with the impactor and there is no leakage from the hydrogen storage system(s).
- 5.2.1.5. The container(s) (for hydrogen storage) shall remain attached to the vehicle at a minimum of one attachment point.
- 5.2.2. In case of a vehicle equipped with an electric power train operating on high voltage, the electric power train and the high voltage systems which are galvanically connected to the high voltage bus of the electric power train shall meet the requirements in paragraphs 5.2.2.1 to 5.2.2.3.:
- 5.2.2.1. Protection against electrical shock
- After the impact, the high voltage buses shall meet at least one of the four criteria specified in paragraph 5.2.2.1.1 through paragraph 5.2.2.1.4.2 below.
- If the vehicle has an automatic disconnect function, or device(s) that conductively divide the electric power train circuit during driving condition, at least one of the following criteria shall apply to the disconnected circuit or to each divided circuit individually after the disconnect function is activated.
- However, criteria defined in 5.2.2.1.4. below shall not apply if more than a single potential of a part of the high voltage bus is not protected under the conditions of protection degree IPXXB.
- In the case that the crash test is performed under the condition that part(s) of the high voltage system are not energized and with the exception of any coupling system for charging the REESS which is not energized during driving, the protection against electrical shock shall be proved by either paragraph 5.2.2.1.3 or paragraph 5.2.2.1.4 for the relevant part(s).
- 5.2.2.1.1. Absence of high voltage
- The voltages U_b , U_1 and U_2 of the high voltage buses shall be equal or less than 30 VAC or 60 VDC within 60 s after the impact when measured in accordance with paragraph 2 of Annex 5.

5.2.2.1.2. Low electrical energy

The Total Energy (TE) on the high voltage buses shall be less than 0,2 J when measured according to the test procedure as specified in paragraph 3 of Annex 5 with the formula (a). Alternatively, the Total Energy (TE) may be calculated by the measured voltage U_b of the high voltage bus and the capacitance of the X-capacitors (Cx) specified by the manufacturer according to formula (b) of paragraph 3 of Annex 5.

The energy stored in the Y-capacitors (TEy1, TEy2) shall also be less than 0,2 J. This shall be calculated by measuring the voltages U_1 and U_2 of the high voltage buses and the electrical chassis, and the capacitance of the Y-capacitors specified by the manufacturer according to formula (c) of paragraph 3 of Annex 5.

5.2.2.1.3. Physical protection

For protection against direct contact with high voltage live parts, the protection degree IPXXB shall be provided.

The assessment shall be conducted in accordance with paragraph 4 of Annex 5.

In addition, for protection against electrical shock which could arise from indirect contact, the resistance between all exposed conductive parts of electrical protection barriers/enclosures and the electrical chassis shall be lower than 0,1 Ω and the resistance between any two simultaneously reachable exposed conductive parts of electrical protection barriers/enclosures that are less than 2,5 m from each other shall be less than 0,2 Ω when there is current flow of at least 0,2 A. This resistance may be calculated using the separately measured resistances of the relevant parts of electric path.

This requirement is satisfied if the galvanic connection has been made by welding. In case of doubt or the connection is established by means other than welding, measurement shall be made by using one of the test procedures described in paragraph 4 of Annex 5.

5.2.2.1.4. Isolation resistance

The criteria specified in the paragraphs 5.2.2.1.4.1 and 5.2.2.1.4.2 below shall be met.

The measurement shall be conducted in accordance with paragraph 5 of Annex 5.

5.2.2.1.4.1. Electric power train consisting of separate DC- or AC-buses

If the AC high voltage buses and the DC high voltage buses are galvanically isolated from each other, isolation resistance between the high voltage bus and the electrical chassis (R_i , as defined in paragraph 5 of Annex 5) shall have a minimum value of 100 Ω/V of the working voltage for DC buses, and a minimum value of 500 Ω/V of the working voltage for AC buses.

5.2.2.1.4.2. Electric power train consisting of combined DC- and AC-buses

If the AC high voltage buses and the DC high voltage buses are conductively connected, they shall meet one of the following requirements:

- (a) Isolation resistance between the high voltage bus and the electrical chassis shall have a minimum value of 500 Ω/V of the working voltage;
- (b) Isolation resistance between the high voltage bus and the electrical chassis shall have a minimum value of 100 Ω/V of the working voltage and the AC bus meets the physical protection as described in paragraph 5.2.2.1.3;
- (c) Isolation resistance between the high voltage bus and the electrical chassis shall have a minimum value of 100 Ω/V of the working voltage and the AC bus meets the absence of high voltage as described in paragraph 5.2.2.1.1.

5.2.2.2. Electrolyte leakage

5.2.2.2.1. In case of aqueous electrolyte REESS.

For a period from the impact until 60 minutes after the impact, there shall be no electrolyte leakage from the REESS into the passenger compartment and no more than 7 per cent by volume of the REESS electrolyte with a maximum of 5,0 l leaked from the REESS to the outside of the passenger compartment. The leaked amount of electrolyte can be measured by the usual techniques of determining liquid volumes after its collection. For containers containing Stoddard, coloured coolant and electrolyte, the fluids shall be allowed to separate by specific gravity then measured.

5.2.2.2.2. In case of non-aqueous electrolyte REESS.

For a period from the impact until 60 minutes after the impact, there shall be no liquid electrolyte leakage from the REESS into the passenger compartment or luggage compartment and no liquid electrolyte leakage to outside the vehicle. This requirement shall be verified by visual inspection without disassembling any part of the vehicle.

The manufacturer shall demonstrate compliance in accordance with paragraph 6 of Annex 5.

5.2.2.3. REESS retention

REESS shall remain attached to the vehicle by at least one component anchorage, bracket, or any structure that transfers loads from REESS to the vehicle structure, and REESS located outside the passenger compartment shall not enter the passenger compartment.

The manufacturer shall demonstrate compliance in accordance with paragraph 7 of Annex 5.

6. TEST

6.1. The vehicle's compliance with the requirements of paragraph 5 above shall be checked by the method set out in Annex 3, Annex 4 and Annex 5 to this Regulation

7. MODIFICATIONS AND EXTENSION OF APPROVAL OF THE VEHICLE TYPE

7.1. Every modification of the vehicle type with regard to this Regulation shall be notified to the Type Approval Authority which approved that vehicle type. The Type Approval Authority may then either:

- (a) Decide, in consultation with the manufacturer, that a new type approval is to be granted; or
- (b) Apply the procedure contained in paragraph 7.1.1 (Revision) and, if applicable, the procedure contained in paragraph 7.1.2 (Extension).

7.1.1. Revision

When particulars recorded in the information documents of Annex 1 – Appendix 1 have changed and the Type Approval Authority considers that the modifications made are unlikely to have appreciable adverse effect, and that in any case the vehicle still meets the requirements, the modification shall be designated a 'revision'.

In such a case, the Type Approval Authority shall issue the revised pages of the information documents of Annex 1 – Appendix 1 as necessary, marking each revised page to show clearly the nature of the modification and the date of re-issue. A consolidated, updated version of the information documents of Annex 1 – Appendix 1, accompanied by a detailed description of the modification, shall be deemed to meet this requirement.

7.1.2. Extension

The modification shall be designated an 'extension' if, in addition to the change of the particulars recorded in the information folder:

- (a) Further inspections or tests are required; or
- (b) Any information on the communication document (with the exception of its attachments) has changed; or
- (c) Approval to a later series of amendments is requested after its entry into force.

7.2. Notice of confirmation, extension, or refusal of approval shall be communicated by the procedure specified in paragraph 4.3 above, to the Contracting Parties to the Agreement applying this Regulation. In addition, the index to the information documents and to the test reports, attached to the communication document of Annex 1, shall be amended accordingly to show the date of the most recent revision or extension.

7.3. The Type Approval Authority issuing the extension of approval shall assign a series number to each communication form drawn up for such an extension.

8. CONFORMITY OF PRODUCTION

The conformity of production procedures shall comply with those set out in the Agreement, Schedule 1 (E/ECE/TRANS/505/Rev.3), with the following requirements:

8.1. Every vehicle bearing an approval mark as prescribed under this Regulation shall conform to the vehicle type approved by meeting the requirements set out in paragraph 5 above.

9. PENALTIES FOR NON-CONFORMITY OF PRODUCTION

9.1. The approval granted in respect of a vehicle type pursuant to this Regulation may be withdrawn if the requirements laid down in paragraph 8.1 above is not complied with.

9.2. If a Contracting Party to the Agreement which applies this Regulation withdraws an approval it has previously granted, it shall forthwith notify the other Contracting Parties applying this Regulation by means of a copy of the approval form bearing at the end, in large letters, the signed and dated annotation 'APPROVAL WITHDRAWN'.

10. PRODUCTION DEFINITELY DISCONTINUED

If the holder of the approval completely ceases to manufacture the vehicle type approved in accordance with this Regulation, he shall so inform the Type Approval Authority which granted the approval. Upon receiving the relevant communication that Type Approval Authority shall inform thereof the other Contracting Parties applying this Regulation by means of a copy of the approval form bearing at the end, in large letters, the signed and dated annotation 'PRODUCTION DISCONTINUED'.

11. NAMES AND ADDRESSES OF TECHNICAL SERVICES RESPONSIBLE FOR CONDUCTING APPROVAL TESTS AND OF TYPE APPROVAL AUTHORITIES

The Contracting Parties to the Agreement applying this Regulation shall communicate to the Secretariat of the United Nations the names and addresses of the Technical Services responsible for conducting approval tests and of the Type Approval Authorities which grant approval and to which forms certifying approval or refusal, or extension or withdrawal of approval, issued in the other countries, are to be sent.

ANNEX 1

Communication

(Maximum format: A4 (210 × 297 mm))



Issued by:

Name of administration:

.....
.....
.....

Concerning (²) :

- Approval granted
- Approval extended
- Approval refused
- Approval withdrawn
- Production definitively discontinued

of a vehicle type with regard to fuel system integrity and with regard to the safety of electric power train in a rear-end collision, pursuant to UN Regulation 153

Approval No Extension No:

1. Trade name or mark of the power-driven vehicle
2. Vehicle type
3. Manufacturer's name and address
4. If applicable, name and address of manufacturer's representative:
5. Brief description of the vehicle type
- 5.1. Description of the fuel system installed in the vehicle
- 5.2. Description of the electric power train
6. Site of engine: forward/rear/central (²)
7. Drive: front-wheel/rear-wheel (²)
8. Mass of vehicle submitted for testing:
 - Front axle:
 - Rear axle:
 - Total:

- 9. Vehicle submitted for approval on
 - 10. Technical Service responsible for conducting approval tests
 - 11. Date of report issued by that Service
 - 12. Number of reports issued by that Service
 - 13. Approval granted/refused/extended/withdrawn ^(?)
 - 14. Position of approval mark on vehicle
 - 15. Place
 - 16. Date
 - 17. Signature
 - 18. The following documents, bearing the approval number shown above, are annexed to this communication:
 - 19. Remarks (e.g. alternative test method according to Annex 3, paragraph 3 applied.)
- (Photographs and/or diagrams and drawings permitting the basic identification of the type(s) of vehicle and its possible variants which are covered by the approval)

⁽¹⁾ Distinguishing number of the country which has granted/extended/refused/withdrawn an approval (see approval provisions in the Regulation).
⁽²⁾ Strike out what does not apply

*Appendix 1 to Annex 1***Information document**

- 0. GENERAL
 - 0.1. Make (trade name of manufacturer):
 - 0.2. Type:
 - 0.2.1. Commercial name(s) (if available):
 - 0.3. Means of identification of type, if marked on the vehicle ⁽¹⁾:
 - 0.3.1. Location of that marking:
 - 0.4. Category of vehicle ⁽²⁾:
 - 0.5. Company name and address of manufacturer:
 - 0.8. Name(s) and Address(es) of assembly plant(s):
 - 0.9. Name and address of the manufacturer's representative (if any):
- 1. GENERAL CONSTRUCTION CHARACTERISTICS OF THE VEHICLE
 - 1.1. Photographs and/or drawings of a representative vehicle
 - 1.3. Number of axles and wheels:
 - 1.3.3. Powered axles (number, position, interconnection):
 - 1.6. Position and arrangement of the engine:
- 2. MASSES AND DIMENSIONS (in kg and mm) (Refer to drawing where applicable)
 - 2.1. Wheelbase(s) (fully loaded)
 - 2.1.1. Two-axle vehicles:
 - 2.1.2. Vehicles with three or more axles
 - 2.1.2.2. Total axle spacing:
 - 2.4. Range of vehicle dimensions (overall)
 - 2.4.1. For chassis without bodywork
 - 2.4.1.1. Length (mm):
 - 2.4.1.2. Width (mm):
 - 2.4.2. For chassis with bodywork
 - 2.4.2.1. Length (mm):
 - 2.4.2.2. Width (mm)

- 2.6. Mass in running order (kg):
- 3. PROPULSION ENERGY CONVERTER
 - 3.2.2. Fuel
 - 3.2.2.1. Light-duty vehicles: Diesel/Petrol/LPG/NG or Biomethane/Ethanol (E 85)/Biodiesel/Hydrogen
 - 3.2.3. Fuel tank(s)
 - 3.2.3.1. Service fuel tank(s)
 - 3.2.3.1.1. Number and capacity of each tank:
 - 3.2.3.1.1.1. Material
 - 3.2.3.1.2. Drawing and technical description of the tank(s) with all connections and all lines of the breathing and venting system, locks, valves, fastening devices
 - 3.2.3.1.3. Drawing clearly showing the position of the tank(s) in the vehicle
 - 3.2.3.2. Reserve fuel tank(s)
 - 3.2.3.2.1. Number and capacity of each tank:
 - 3.2.3.2.1.1. Material
 - 3.2.3.2.2. Drawing and technical description of the tank(s) with all connections and all lines of the breathing and venting system, locks, valves, fastening devices
 - 3.2.3.2.3. Drawing clearly showing the position of the tank(s) in the vehicle
- 3.3.2. REESS
 - 3.3.2.4. Position
- 3.4. Combinations of propulsion energy converters
 - 3.4.1. Hybrid electric vehicle: yes/no
 - 3.4.2. Category of hybrid electric vehicle: off-vehicle charging/not off-vehicle charging:

(¹) If the means of identification of type contains characters which are not relevant to describing the vehicle, i.e. types covered by the type-approval certificate, such characters shall be represented in the documentation by the symbol '?' (e.g. ABC??123??).

(²) As defined in the Consolidated Resolution on the Construction of Vehicles (R.E.3.), document ECE/TRANS/WP.29/78/Rev.6, para. 2. – www.unece.org/trans/main/wp29/wp29wgs/wp29gen/wp29resolutions.html

ANNEX 2

Arrangements of approval marks

MODEL A

(See paragraph 4.4 of this Regulation)

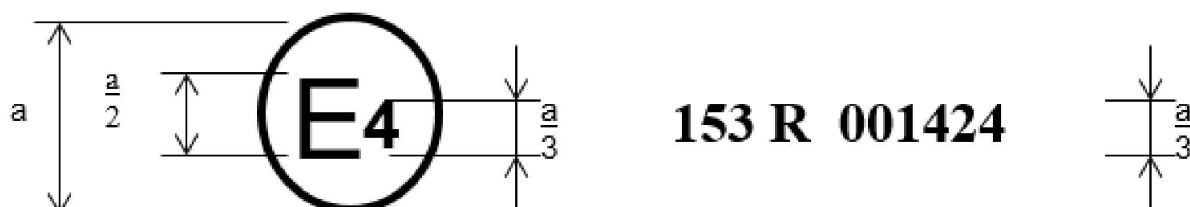

a = 8 mm min.

The above approval mark affixed to a vehicle shows that the vehicle type concerned has, with regard to the protection of the occupants in the event of a rear-end collision, been approved in the Netherlands (E 4) pursuant to UN Regulation No 153 under approval number 001424. The approval number indicates that the approval was granted in accordance with the requirements of UN Regulation No 153 in its original form.

MODEL B

(See paragraph 4.5 of this Regulation)

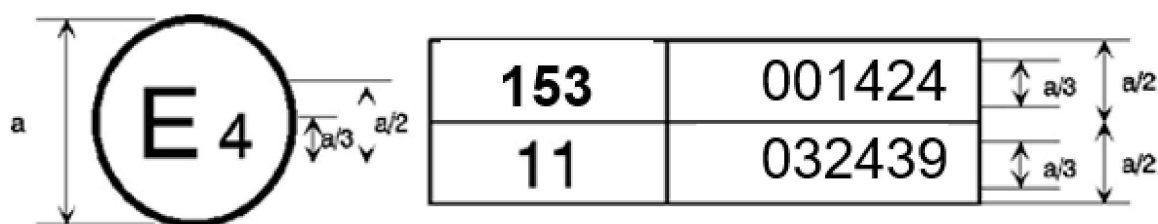

a = 8 mm min.

The first two digits of the approval numbers indicate that, at the dates when the respective approvals were granted, UN Regulation No 153 was in its original version and UN Regulation No 11 incorporated the 03 series of amendments

ANNEX 3

Procedure for rear-end impact test

1. Purpose
 - 1.1. The purpose of the test is to simulate the conditions of rear-end impact by another vehicle in motion.
2. Installations, procedures and measuring instruments
 - 2.1. Testing ground

The test area shall be large enough to accommodate the impactor (striker) propulsion system and to permit after-impact displacement of the vehicle impacted and installation of the test equipment. The part of which vehicle impact and displacement occur shall be horizontal, flat and smooth and representative of a normal, dry, uncontaminated road surface.
 - 2.2. Impactor (striker)
 - 2.2.1. The impactor shall be of steel and of rigid construction.
 - 2.2.2. The impacting surface shall be flat, not less than 2 500 mm wide, and 800 mm high, and its edges shall be rounded to a radius of curvature of between 40 and 50 mm. It shall be covered with plywood boards 20 ± 2 mm thick.
 - 2.2.3. At the moment of impact, the following requirements shall be met:
 - 2.2.3.1. The impacting surface shall be vertical and perpendicular to the median longitudinal plane of the impacted vehicle;
 - 2.2.3.2. The direction of movement of the impactor shall be substantially horizontal and parallel to the median longitudinal plane of the impacted vehicle;
 - 2.2.3.3. The maximum lateral deviation tolerated between the median vertical line of the surface of the impactor and the median longitudinal plane of the impacted vehicle shall be 300 mm. In addition, the impacting surface shall extend over the entire width of the impacted vehicle;
 - 2.2.3.4. The ground clearance of the lower edge of the impact surface shall be 175 ± 25 mm.
 - 2.3. Propulsion of the impactor

The impactor shall be secured to a carriage (movable barrier).
 - 2.4. Provisions for a movable barrier test
 - 2.4.1. If the impactor is secured to a carriage (movable barrier) by a restraining element, the latter must be rigid and be incapable of being deformed by the impact; the carriage shall at the moment of impact be capable of moving freely and no longer be subject to the action of the propelling device.
 - 2.4.2. The velocity of the impact shall be $50,0 \pm 2,0$ km/h.
 - 2.4.3. The aggregate mass of carriage and impactor shall be $1\ 100 \pm 20$ kg.

2.5. General provisions on the mass and velocity of the impactor

If the test has been conducted at an impact velocity higher than those prescribed in paragraph 2.4.2 and the vehicle has met the requirements prescribed, the test shall be considered satisfactory.

2.6. State of vehicle under test

2.6.1. The vehicle under test shall either be fitted with all the normal components and equipment included in its unladen mass or be in such condition as to fulfil this requirement so far as the components and equipment of concern to the passenger compartment and the distribution of the weight of the vehicle as a whole, in running order, are concerned.

2.6.2. The tank for liquid fuel shall be filled to at least 90 per cent of its capacity either with fuel or with a non-flammable liquid having a density and a viscosity close to those of the fuel normally used. All other systems (brake-fluid header tanks, radiator, Selective Catalytic Reduction reagents, etc.) may be empty.

The compressed hydrogen storage system(s) and enclosed spaces of compressed hydrogen-fuelled vehicles shall be prepared in accordance with paragraph 3 of Annex 4.

2.6.3 The parking brake is disengaged and the transmission/gear lever is in neutral.

2.6.4. If the manufacturer so requests, the following derogations shall be permitted:

2.6.4.1. The technical service responsible for conducting the test may allow the same vehicle as is used for test prescribed by other UN Regulations (including tests capable of affecting its structure) to be used for the tests prescribed by this Regulation.

2.6.4.2. The vehicle may be weighted to an extent not exceeding 10 per cent of its unladen mass with additional masses rigidly secured to the structure in such a way as not to affect the fuel system integrity and the safety of electric power train during the test.

2.6.5. Electric power train adjustment

2.6.5.1. The REESS shall be at any state of charge, which allows the normal operation of the power train as recommended by the manufacturer.

2.6.5.2. The electric power train shall be energized with or without the operation of the original electrical energy sources (e.g. engine-generator, REESS or electric energy conversion system), however:

2.6.5.2.1. By the agreement between Technical Service and manufacturer it shall be permissible to perform the test with all or parts of the electric power train not being energized insofar as there is no negative influence on the test result. For parts of the electric power train not energized, the protection against electrical shock shall be proved by either physical protection or isolation resistance and appropriate additional evidence.

2.6.5.2.2. In the case where an automatic disconnect is provided, at the request of the manufacturer, it shall be permissible to perform the test with the automatic disconnect being triggered. In this case it shall be demonstrated that the automatic disconnect would have operated during the impact test. This includes the automatic activation signal as well as the galvanic separation considering the conditions as seen during the impact.

2.7. Measuring Instruments

The instruments used to record the speed referred to in paragraph 2.4.2 above shall be accurate to within 1 per cent.

3. Alternative test methods

At the request of manufacturer, the following test method may be used as an alternative to the test method prescribed in paragraph 2 above.

3.1. An offset rear impact test with a movable deformable barrier is accepted as alternative to the procedure described in paragraph 2 of this annex if the conditions laid down in paragraphs 3.1.1 to 3.1.3 are fulfilled.

3.1.1. Impact speed

The impact speed shall be between 78,5 km/h and 80,1 km/h.

3.1.2. Offset vehicle to barrier

The overlap between car and barrier shall be 70 per cent.

3.1.3. Movable Deformable Barrier (MDB)

The movable deformable barrier shall meet following specifications:

- (a) The total weight of MDB with impact face shall be $1\,361 \pm 4,5$ kg;
- (b) The overall length of MDB with impact face shall be $4\,115 \text{ mm} \pm 25$ mm;
- (c) The overall length of MDB excluding impact face shall be $3\,632$ mm (includes 50,8 mm thick mounting block);
- (d) The overall width of framework carriage shall be $1\,251$ mm;
- (e) The tracking width (centreline to centreline of front or rear wheels) shall be $1\,880$ mm;
- (f) The wheelbase for framework carriage shall be $2\,591 \text{ mm} \pm 25$ mm;
- (g) Inertial properties of the MDB (with two cameras and camera mounts and a light trap vane and ballast reduced); the centre of gravity (CG) is as follows:

$X = (1\,123 \pm 25)$ mm rear of front axle

$Y = (7,6 \pm 25)$ mm left of longitudinal centreline

$Z = (450 \pm 25)$ mm from ground

Moments of inertia (tolerance 5 per cent for testing purposes) are as follows:

Pitch = $2\,263 \text{ kg}\cdot\text{m}^2$

Roll = $508 \text{ kg}\cdot\text{m}^2$

Yaw = $2\,572 \text{ kg}\cdot\text{m}^2$

- (h) Shape of honeycomb impact face:

Width = $1\,676 \text{ mm} \pm 6$ mm

Height = $559 \text{ mm} \pm 6$ mm

Ground Clearance = $229 \text{ mm} \pm 3$ mm

Depth at Bumper Height = $483 \text{ mm} \pm 6$ mm

Depth at upper impact face = $381 \text{ mm} \pm 6$ mm

- (i) Force-deflection properties (crush strength) for honeycomb impact face shall be $310 \text{ kPa} \pm 17 \text{ kPa}$ and $1\,690 \text{ kPa} \pm 103 \text{ kPa}$ for the bumper.

Other parameters and settings may be similar to the definitions in paragraph 2 of this Regulation.

3.2. If a method other than that described in paragraph 2 or paragraph 3.1 above is used, its equivalence shall be demonstrated.

ANNEX 4

Test conditions and procedures for the assessment of post-crash hydrogen fuel system integrity

1. Purpose

Determination of compliance with the requirements of paragraph 5.2.1 of this Regulation.

2. Definitions

For the purposes of this annex:

2.1. 'Enclosed spaces' indicates the special volumes within the vehicle (or the vehicle outline across openings) that are external to the hydrogen system (storage system, fuel cell system and fuel flow management system) and its housings (if any) where hydrogen may accumulate (and thereby pose a hazard), such as the passenger compartment, luggage compartment and space under the hood.

2.2. 'Luggage compartment' is the space in the vehicle for luggage and/or goods accommodation, bounded by the roof, hood, floor, side walls, being separated from the passenger compartment by the front bulkhead or the rear bulkhead.

2.3. 'Nominal working pressure (NWP)' is the gauge pressure that characterizes typical operation of a system. For compressed hydrogen gas containers, NWP is the settled pressure of compressed gas in a fully fuelled container or storage system at a uniform temperature of 15 °C.

3. Preparation, instrumentation and test conditions

3.1. Compressed hydrogen storage systems and downstream piping

3.1.1. Prior to conducting the crash test, instrumentation is installed in the hydrogen storage system to perform the required pressure and temperature measurements if the standard vehicle does not already possess instrumentation with the required accuracy.

3.1.2. The hydrogen storage system is then purged, if necessary, following manufacturer directions to remove impurities from the container before filling the storage system with compressed hydrogen or helium gas. Since the storage system pressure varies with temperature, the targeted fill pressure is a function of the temperature. The target pressure shall be determined from the following equation:

$$P_{\text{target}} = \text{NWP} \times (273 + T_o) / 288$$

where NWP is the nominal working pressure (MPa), T_o is the ambient temperature to which the storage system is expected to settle, and P_{target} is the targeted fill pressure after the temperature settles.

3.1.3. The container is filled to a minimum of 95 per cent of the targeted fill pressure and allowed to settle (stabilize) prior to conducting the crash test.

3.1.4. The main stop valve and shut-off valves for hydrogen gas, located in the downstream hydrogen gas piping, are in normal driving condition immediately prior to the impact.

3.2. Enclosed spaces

3.2.1. Sensors are selected to measure either the build-up of the hydrogen or helium gas or the reduction in oxygen (due to displacement of air by leaking hydrogen/helium).

- 3.2.2. Sensors are calibrated to traceable references to ensure an accuracy of ± 5 per cent at the targeted criteria of 4 per cent hydrogen or 3 per cent helium by volume in air, and a full scale measurement capability of at least 25 per cent above the target criteria. The sensor shall be capable of a 90 per cent response to a full scale change in concentration within 10 seconds.
- 3.2.3. Prior to the crash impact, the sensors are located in the passenger and luggage compartments of the vehicle as follows:
- At a distance within 250 mm of the headliner above the driver's seat or near the top centre of the passenger compartment;
 - At a distance within 250 mm of the floor in front of the rear (or rear most) seat in the passenger compartment; and
 - At a distance within 100 mm of the top of luggage compartments inside the vehicle that are not directly affected by the particular crash impact to be conducted.
- 3.2.4. The sensors are securely mounted on the vehicle structure or seats and protected for the planned crash test from debris, air bag exhaust gas and projectiles. The measurements following the crash are recorded by instruments located in the vehicle or by remote transmission.
- 3.2.5. The test may be conducted either outdoors in an area protected from the wind and possible solar effects, or indoors in a space that is large enough or ventilated to prevent the build-up of hydrogen to more than 10 per cent of the targeted criteria in the passenger and luggage compartments.
4. Post-crash leak test measurement for a compressed hydrogen storage system filled with compressed hydrogen

- 4.1. The hydrogen gas pressure, P_o (MPa), and temperature, T_o ($^{\circ}\text{C}$), are measured immediately before the impact and then at a time interval, Δt (min), after the impact.
- 4.1.1. The time interval, Δt , starts when the vehicle comes to rest after the impact and continues for at least 60 minutes.

- 4.1.2. The time interval, Δt shall be increased if necessary in order to accommodate measurement accuracy for a storage system with a large volume operating up to 70 MPa; in that case, Δt can be calculated from the following formula:

$$\Delta t = V_{\text{CHSS}} \times \text{NWP} / 1\,000 \times ((-0,027 \times \text{NWP} + 4) \times R_s - 0,21) - 1,7 \times R_s$$

where $R_s = P_s / \text{NWP}$, P_s is the pressure range of the pressure sensor (MPa), NWP is the Nominal Working Pressure (MPa), V_{CHSS} is the volume of the compressed hydrogen storage system (L), and Δt is the time interval (min).

- 4.1.3. If the calculated value of Δt is less than 60 minutes, Δt is set to 60 minutes.

- 4.2. The initial mass of hydrogen in the storage system can be calculated as follows:

$$P_o' = P_o \times 288 / (273 + T_o)$$

$$\rho_o' = -0,0027 \times (P_o')^2 + 0,75 \times P_o' + 0,5789$$

$$M_o = \rho_o' \times V_{\text{CHSS}}$$

- 4.3. Correspondingly, the final mass of hydrogen in the storage system, M_f , at the end of the time interval, Δt , can be calculated as follows:

$$P_f' = P_f \times 288 / (273 + T_f)$$

$$\rho_f' = -0,0027 \times (P_f')^2 + 0,75 \times P_f' + 0,5789$$

$$M_f = \rho_f' \times V_{\text{CHSS}}$$

where P_f is the measured final pressure (MPa) at the end of the time interval, and T_f is the measured final temperature ($^{\circ}\text{C}$).

- 4.4. The average hydrogen flow rate over the time interval is therefore:

$$V_{H_2} = (M_f - M_o) / \Delta t \times 22,41 / 2,016 \times (P_{\text{target}} / P_o)$$

where V_{H_2} is the average volumetric flow rate (NL/min) over the time interval and the term (P_{target}/P_o) is used to compensate for differences between the measured initial pressure (P_o) and the targeted fill pressure (P_{target}).

5. Post-crash leak test measurement for a compressed hydrogen storage system filled with compressed helium
- 5.1. The helium gas pressure, P_o (MPa), and temperature T_o (°C), are measured immediately before the impact and then at a predetermined time interval after the impact.

- 5.1.1. The time interval, Δt , starts when the vehicle comes to rest after the impact and continues for at least 60 minutes.

- 5.1.2. The time interval, Δt , shall be increased, if necessary, in order to accommodate measurement accuracy for a storage system with a large volume operating up to 70 MPa; in that case, Δt can be calculated from the following equation:

$$\Delta t = V_{\text{CHSS}} \times \text{NWP} / 1\,000 \times ((-0,028 \times \text{NWP} + 5,5) \times R_s - 0,3) - 2,6 \times R_s$$

where $R_s = P_s / \text{NWP}$, P_s is the pressure range of the pressure sensor (MPa), NWP is the Nominal Working Pressure (MPa), V_{CHSS} is the volume of the compressed hydrogen storage system (L), and Δt is the time interval (min).

- 5.1.3. If the value of Δt is less than 60 minutes, Δt is set to 60 minutes.

- 5.2. The initial mass of helium in the storage system is calculated as follows:

$$P_o' = P_o \times 288 / (273 + T_o)$$

$$\rho_o' = -0,0043 \times (P_o')^2 + 1,53 \times P_o' + 1,49$$

$$M_o = \rho_o' \times V_{\text{CHSS}}$$

- 5.3. The final mass of helium in the storage system at the end of the time interval, Δt , is calculated as follows:

$$P_f' = P_f \times 288 / (273 + T_f)$$

$$\rho_f' = -0,0043 \times (P_f')^2 + 1,53 \times P_f' + 1,49$$

$$M_f = \rho_f' \times V_{\text{CHSS}}$$

where P_f is the measured final pressure (MPa) at the end of the time interval, and T_f is the measured final temperature (°C).

- 5.4. The average helium flow rate over the time interval is therefore:

$$V_{\text{He}} = (M_f - M_o) / \Delta t \times 22,41 / 4,003 \times (P_{\text{target}} / P_o)$$

where V_{He} is the average volumetric flow rate (NL/min) over the time interval and the term (P_{target}/P_o) is used to compensate for differences between the measured initial pressure (P_o) and the targeted fill pressure (P_{target}).

- 5.5. Conversion of the average volumetric flow of helium to the average hydrogen flow is calculated with the following formula:

$$V_{H_2} = V_{\text{He}} / 0,75$$

where V_{H_2} is the corresponding average volumetric flow of hydrogen.

6. Post-crash concentration measurement for enclosed spaces
 - 6.1. Post-crash data collection in enclosed spaces commences when the vehicle comes to a rest. Data from the sensors installed in accordance with paragraph 3.2 of this annex are collected at least every 5 seconds and continue for a period of 60 minutes after the test. A first-order lag (time constant) up to a maximum of 5 seconds may be applied to the measurements to provide 'smoothing' and filter the effects of spurious data points.
-

ANNEX 5

Test procedures for the vehicles equipped with electric power train

This annex describes test procedures to demonstrate compliance to the electrical safety requirements of paragraph 5.2.2 of this Regulation.

1. Test setup and equipment

If a high voltage disconnect function is used, measurements are to be taken from both sides of the device performing the disconnect function. However, if the high voltage disconnect is integral to the REESS or the energy conversion system and the high-voltage bus of the REESS or the energy conversion system is protected according to protection degree IPXXB following the impact test, measurements may only be taken between the device performing the disconnect function and the electrical loads.

The voltmeter used in this test shall measure DC values and have an internal resistance of at least 10 M Ω .

2. The following instructions may be used if voltage is measured.

After the impact test, determine the high voltage bus voltages (U_b , U_1 , U_2) (see Figure 1 below).

The voltage measurement shall be made not earlier than 10 seconds, but, not later than 60 seconds after the impact.

This procedure is not applicable if the test is performed under the condition where the electric power train is not energized.

Figure 1

Measurement of U_b , U_1 , U_2

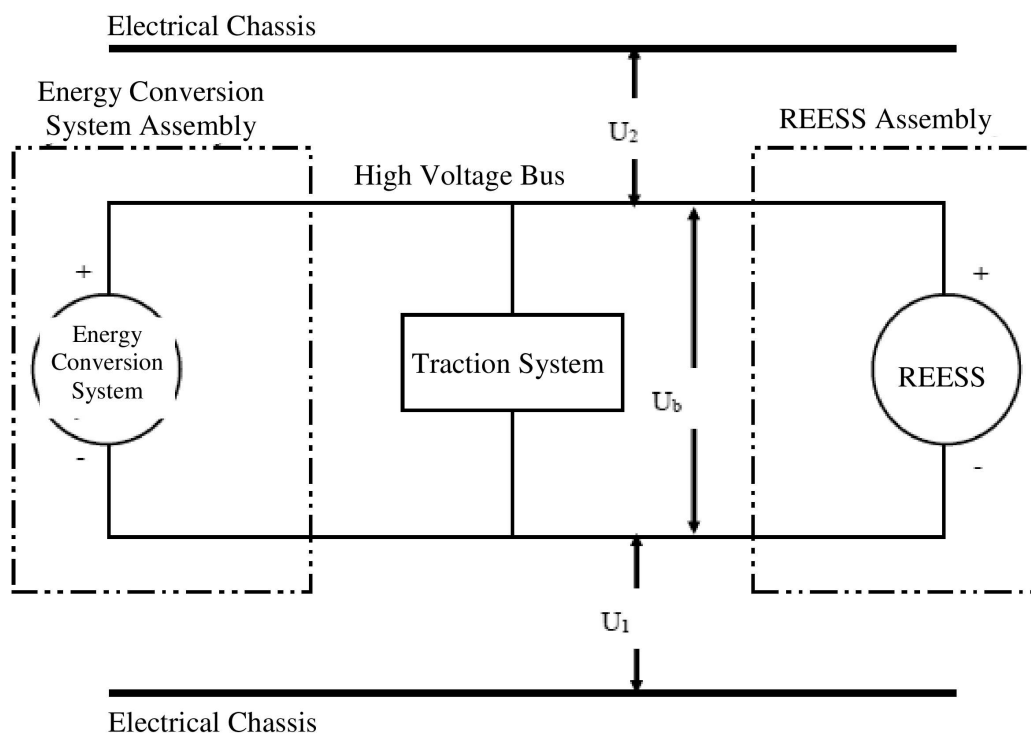

3. Assessment procedure for low electrical energy

Prior to the impact a switch S1 and a known discharge resistor Re is connected in parallel to the relevant capacitance (ref. Figure 2 below).

- (a) Not earlier than 10 seconds and not later than 60 seconds after the impact the switch S1 shall be closed while the voltage U_b and the current I_e are measured and recorded. The product of the voltage U_b and the current I_e shall be integrated over the period of time, starting from the moment when the switch S1 is closed (t_c) until the voltage U_b falls below the high voltage threshold of 60 V DC (t_h). The resulting integration equals the Total Energy (TE) in joules.

$$TE = \int_{t_c}^{t_h} U_b \times I_e dt$$

- (b) When U_b is measured at a point in time between 10 seconds and 60 seconds after the impact and the capacitance of the X-capacitors (C_x) is specified by the manufacturer, Total Energy (TE) shall be calculated according to the following formula:

$$TE = 0,5 \times C_x \times U_b^2$$

- (c) When U_1 and U_2 (see Figure 1 above) are measured at a point in time between 10 seconds and 60 seconds after the impact and the capacitances of the Y-capacitors (C_{y1} , C_{y2}) are specified by the manufacturer, Total Energy (TE_{y1} , TE_{y2}) shall be calculated according to the following formulas:

$$TE_{y1} = 0,5 \times C_{y1} \times U_1^2$$

$$TE_{y2} = 0,5 \times C_{y2} \times U_2^2$$

This procedure is not applicable if the test is performed under the condition where the electric power train is not energized.

Figure 2

e.g. measurement of high voltage bus energy stored in X-capacitors

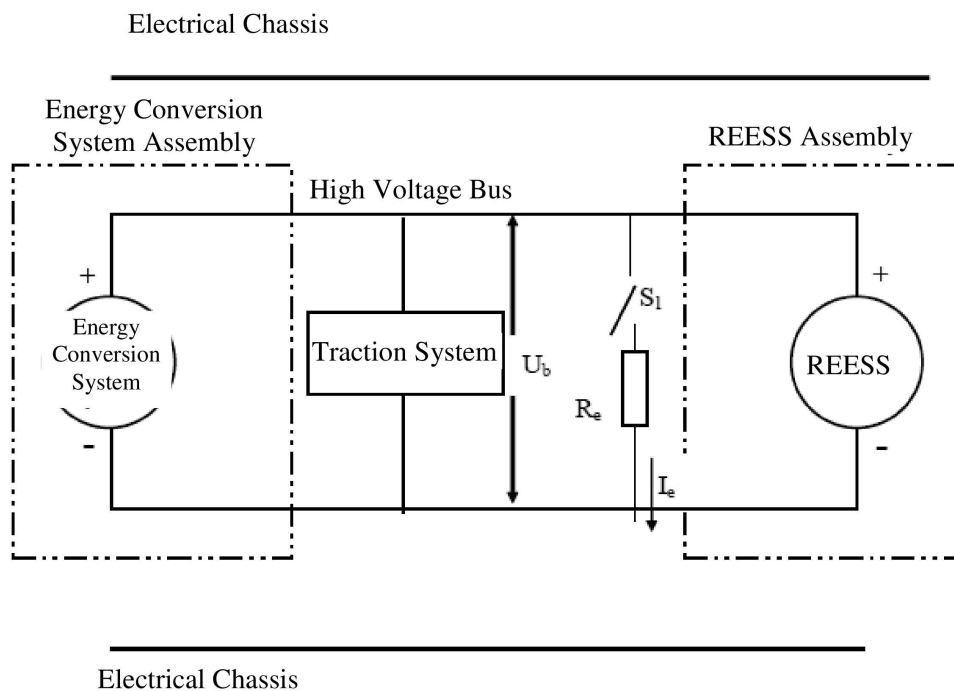

4. Physical protection

Following the vehicle impact test any parts surrounding the high voltage components shall be, without the use of tools, opened, disassembled or removed. All remaining surrounding parts shall be considered part of the physical protection.

The jointed test finger described in Figure 3 shall be inserted into any gaps or openings of the physical protection with a test force of $10\text{ N} \pm 10\text{ per cent}$ for electrical safety assessment. If partial or full penetration into the physical protection by the jointed test finger occurs, the jointed test finger shall be placed in every position as specified below.

Starting from the straight position, both joints of the test finger shall be rotated progressively through an angle of up to 90° with respect to the axis of the adjoining section of the finger and shall be placed in every possible position.

Internal electrical protection barriers are considered part of the enclosure.

If appropriate a low-voltage supply (of not less than 40 V and not more than 50 V) in series with a suitable lamp should be connected, between the jointed test finger and high voltage live parts inside the electrical protection barrier or enclosure.

Figure 3

Joint Test Finger

IPXXB

Jointed test finger

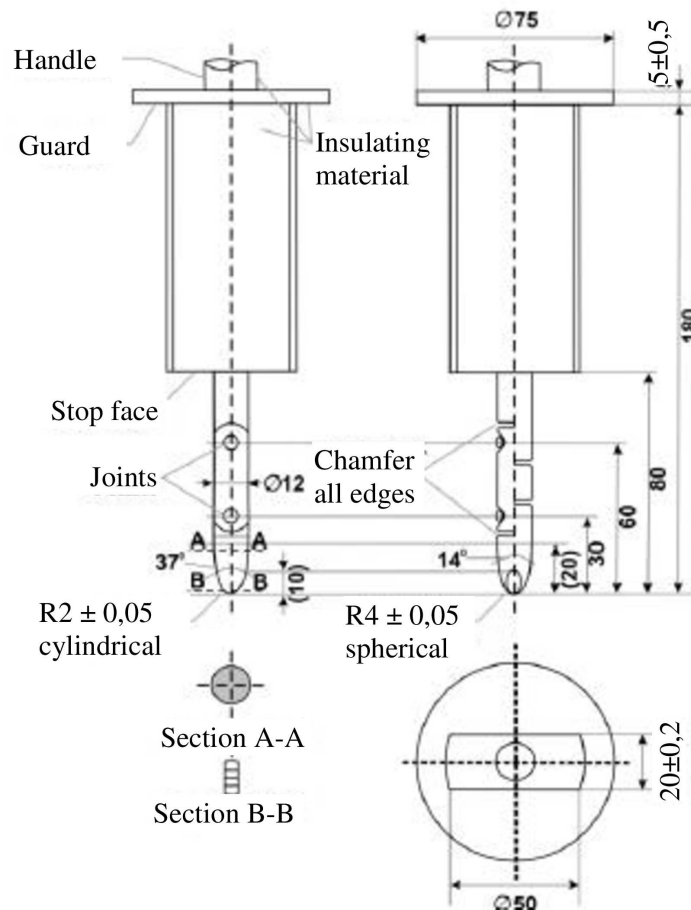

Material: metal, except where otherwise specified

Linear dimensions in mm.

Tolerances on dimensions without specific tolerance:

(a) On angles: $+ 0^{\circ}0'0''/- 0^{\circ}0'10''$;

(b) On linear dimensions:

(i) ≤ 25 mm: $+ 0/- 0,05$ mm;

(ii) > 25 mm: $\pm 0,2$ mm

Both joints shall permit movement in the same plane and the same direction through an angle of 90° with a 0 to $+ 10^{\circ}$ tolerance.

The requirements of paragraph 5.2.2.1.3 of this Regulation are met if the jointed test finger described in Figure 3, is unable to contact high voltage live parts.

If necessary, a mirror or a fiberscope may be used to inspect whether the jointed test finger touches the high voltage buses.

If this requirement is verified by a signal circuit between the jointed test finger and high voltage live parts, the lamp shall not light.

4.1. Test method for measuring electric resistance:

(a) Test method using a resistance tester.

The resistance tester is connected to the measuring points (typically, the electrical chassis and electro conductive enclosure/electrical protection barrier) and the resistance is measured using a resistance tester that meets the specification that follows:

(i) Resistance tester: Measurement current at least $0,2$ A;

(ii) Resolution: $0,01 \Omega$ or less;

(iii) The resistance R shall be less than $0,1 \Omega$.

(b) Test method using DC power supply, voltmeter and ammeter.

The DC power supply, voltmeter and ammeter are connected to the measuring points (Typically, electrical chassis and electro conductive enclosure/electrical protection barrier).

The voltage of the DC power supply is adjusted so that the current flow becomes at least $0,2$ A.

The current 'I' and the voltage 'U' are measured.

The resistance 'R' is calculated according to the following formula:

$$R = U / I$$

The resistance R shall be less than $0,1 \Omega$.

Note: If lead wires are used for voltage and current measurement, each lead wire shall be independently connected to the electrical protection barrier/enclosure/electrical chassis. Terminal can be common for voltage measurement and current measurement.

Example of the test method using DC power supply, voltmeter and ammeter is shown below.

Figure 4

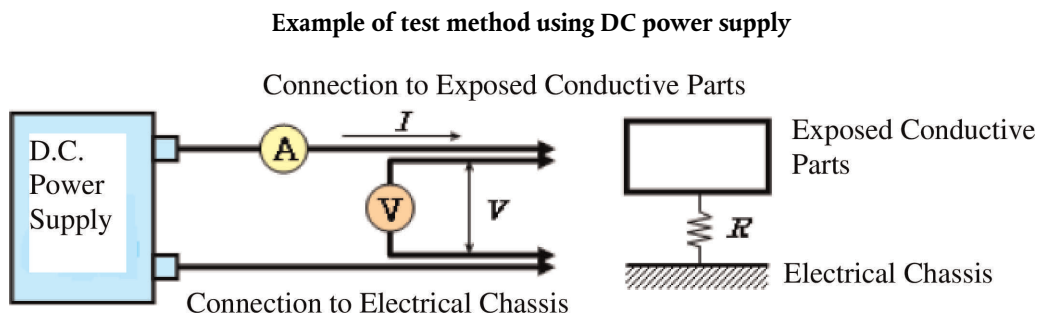

5. Isolation resistance

5.1. General

The isolation resistance for each high voltage bus of the vehicle is measured or shall be determined by calculating the measurement values of each part or component unit of a high voltage bus.

All measurements for calculating voltage(s) and electrical isolation are made after a minimum of 10 s after the impact.

5.2. Measurement method.

The isolation resistance measurement is conducted by selecting an appropriate measurement method from among those listed in paragraphs 5.2.1 to 5.2.2 of this annex, depending on the electrical charge of the live parts or the isolation resistance.

The range of the electrical circuit to be measured is clarified in advance, using electrical circuit diagrams. If the high voltage buses are conductively isolated from each other, isolation resistance shall be measured for each electrical circuit.

Moreover, modifications necessary for measuring the isolation resistance may be carried out, such as removal of the cover in order to reach the live parts, drawing of measurement lines and change in software.

In cases where the measured values are not stable due to the operation of the on-board isolation resistance monitoring system, necessary modifications for conducting the measurement may be carried out by stopping the operation of the device concerned or by removing it. Furthermore, when the device is removed, a set of drawings will be used to prove that the isolation resistance between the live parts and the electrical chassis remains unchanged.

These modifications shall not influence the test results.

Utmost care shall be exercised to avoid short circuit and electric shock since this confirmation might require direct operations of the high-voltage circuit.

5.2.1. Measurement method using DC voltage from external sources.

5.2.1.1. Measurement instrument.

An isolation resistance test instrument capable of applying a DC voltage higher than the working voltage of the high voltage bus shall be used.

5.2.1.2. Measurement method.

An isolation resistance test instrument is connected between the live parts and the electrical chassis. The isolation resistance is subsequently measured by applying a DC voltage at least half of the working voltage of the high voltage bus.

If the system has several voltage ranges (e.g. because of boost converter) in conductively connected circuit and some of the components cannot withstand the working voltage of the entire circuit, the isolation resistance between those components and the electrical chassis can be measured separately by applying at least half of their own working voltage with those components disconnected.

5.2.2. Measurement method using the vehicle's own REESS as DC voltage source.

5.2.2.1. Test vehicle conditions.

The high voltage-bus is energized by the vehicle's own REESS and/or energy conversion system and the voltage level of the REESS and/or energy conversion system throughout the test shall be at least the nominal operating voltage as specified by the vehicle manufacturer.

5.2.2.2. Measurement method.

5.2.2.2.1. First step.

The voltage is measured as shown in Figure 1 and the high voltage bus voltage (U_b) is recorded.

5.2.2.2.2. Second step.

The voltage (U_1) between the negative side of the high voltage bus and the electrical chassis is measured and recorded (see Figure 1).

5.2.2.2.3. Third step.

The voltage (U_2) between the positive side of the high voltage bus and the electrical chassis is measured and recorded (see Figure 1).

5.2.2.2.4. Fourth step.

If U_1 is greater than or equal to U_2 , a standard known resistance (R_0) is inserted between the negative side of the high voltage bus and the electrical chassis. With R_0 installed, the voltage (U_1') between the negative side of the high voltage bus and the electrical chassis is measured (see Figure 5).

The electrical isolation (R_i) is calculated according to the following formula:

$$R_i = R_0 * U_b * (1/U_1' - 1/U_1)$$

Figure 5

Measurement of U_1'

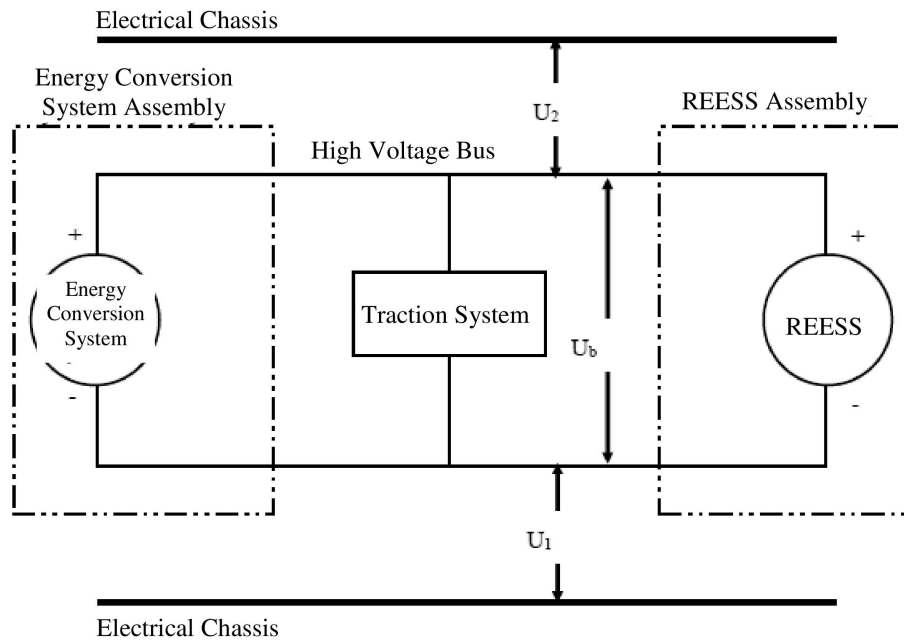

If U_2 is greater than U_1 , insert a standard known resistance (R_0) between the positive side of the high voltage bus and the electrical chassis. With R_0 installed, measure the voltage (U_2') between the positive side of the high voltage bus and the electrical chassis (see Figure 6).

The electrical isolation (R_i) is calculated according to the following formula:

$$R_i = R_0 * U_b * (1/U_2' - 1/U_2)$$

Figure 6

Measurement of U_2'

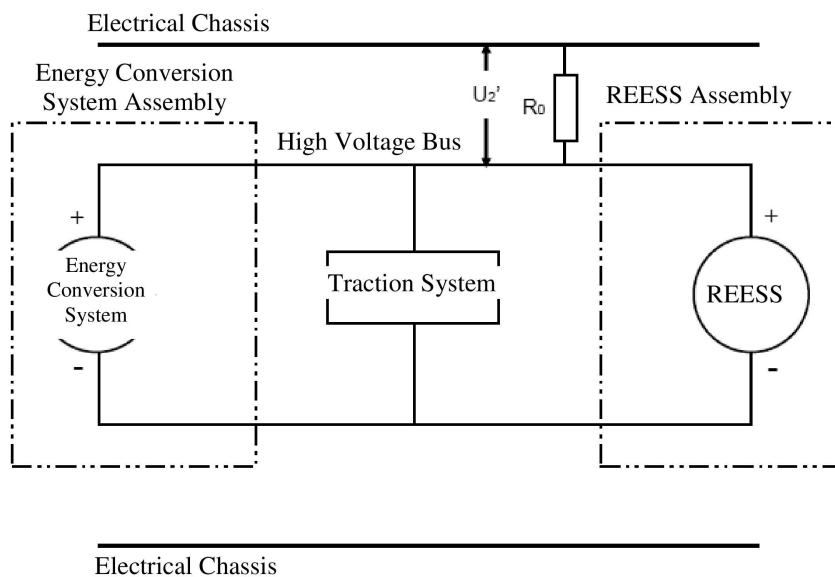

5.2.2.2.5. Fifth step.

The electrical isolation value R_i (in Ω) divided by the working voltage of the high voltage bus (in V) results in the isolation resistance (in Ω/V).

Note: The standard known resistance R_0 (in Ω) should be the value of the minimum required isolation resistance (Ω/V) multiplied by the working voltage (V) of the vehicle plus/minus 20 per cent. R_0 is not required to be precisely this value since the equations are valid for any R_0 ; however, a R_0 value in this range should provide a good resolution for the voltage measurements.

6. Electrolyte leakage

An appropriate coating, if necessary, may be applied to the physical protection (casing) in order to confirm if there is any electrolyte leakage from the REESS after the impact test.

7. REESS retention

Compliance shall be determined by visual inspection.
